

MOV Long Life Grease A Decade Later - Approvals and Lessons Learnt

K. Brown, W. Mackwood and T. Austin

**Presenter: Ted Austin, Forsythe
Lubrication Associates (now with Canoil)**

Toll free 800 305-2806 (now 855 520-2022)

www.forsythe.on.ca (now www.canoilcanadalt.com)

Summary

MOV Long Life was approved by Limatorque in 2002 and this was also the year that EPRI issued their report approving it as a replacement for Exxon Nebula EP for the SMB main gearbox.

This presentation will review;

- The reasons for the change

- The work for the approval

- Limit switch gearbox and stem approvals

- Other actuator approvals

- Some Lessons learnt.

Note this is a 20 minute presentation so not all slides in your handouts will be shown. They were included for reference.

The Requirements

- Must meet Limitorque specifications.
- Be better than the current product and potentially suitable for all applications in an SMB.
- Must pass EQ conditions.
- Must be compatible with Nebula EP.

OEM Requirements

Reference: Limatorque Type SMB Instruction and Maintenance Manual. Reference Bulletin SMBI-82D, Issue 9/90

The eight minimum lubricant qualities are:

1. Should contain an “EP” (*extreme pressure*) additive.
2. Must be suitable for the temperature range intended.
4. Must not create more than 8% swell in Buna N or Viton.
5. Must not contain any grit, abrasive, or fillers.
6. Must slump - prefer NLGI grade 0 to 1.
7. Must not be corrosive to steel gears, ball or roller bearings.
8. Dropping point must be above 316°F for temperature ranges of -20°F to 150°F.

The Rush

The need to find an accepted alternative was given a big push in 2001 when Exxon announced that they would be stopping the manufacture of Nebula EP greases.

In their letter they also reported that Nebula EP had a shelf life of only 1 year so action was required.

Fortunately a lot had already been done.

EPRI Testing – Main Gearbox

Reference: 'Comparative Analysis Of Nebula And MOV Long Life For Limitorque Main Gearbox Applications', Dec 2002

- Bulk Aging -300 Hours At 150°C (300°C)
- Thin Film – 100 Hours At 150°F (300°C)

Bulk Aging Said To Be Equivalent To 27 Years At 54°C (130°F) or 84 Years At 38°C (100°F).

- Thin Film Steam for 24 Hours at 150° (302°F)
- Plus 220 Mrad and EQ (Modified RBOT - now rotating pressure vessel oxidation test)

EPRI Results – Main Gear Box

- MOV Long Life is superior to Nebula EP1 in all key areas with the exception of after thermal aging and irradiation. (Irradiation softened and lowered the dropping point of both greases but with aging Nebula had stiffed from a Grade 1 to a Grade 4 so the DP was affected less.)
- The greases are compatible based on penetration. When mixed the beneficial oxidation resistance of MOV Long Life enhances the poor characteristics of the Nebula.
- Nebula EP was “marginal” in three categories for LOCA condition suitability and being heat resistant.

MOV Long Life – Stems

Reference: 'Rate Of Loading', F. Bensinger (Flowserve), MUG FILE 03J-P07, Handouts Jan 2003

Rate of Loading: Change in Stem Factor for Static and Dynamic Valve Actuations.

$$\text{ROL} = ((\text{SF}_{\text{dynamic}} - \text{SF}_{\text{static}}) / \text{SF}_{\text{static}}) \times 100\%$$

SF = Stem Factor

'Lubricants' Tested; Molykote P37 Paste

Mobilgrease 28

Pure Nickel Special

Never Seeze N-5000

MOV Long Life

Our Note: ROL does not take into account stem nut wear.

MOV Long Life – Stems

Reference: 'Rate Of Loading', F. Bensinger (Flowserve), MUG FILE 03J-P07, Handouts Jan 2003

Conclusions for Inconel Stems – SMB 1-40*

- ROL Varied with Lubricant
- **Lowest ROL with MOV Long Life**
- Highest ROL with Pure Nickel Special
- Polishing Increased ROL
- Best Lubricants (low ROL)

MOV Long Life

Never Seeze N-5000

Molykote P37 Paste

* Similar results with 410T for both Stub and Full ACME threads

Tests were at room temperature.

MOV Long Life – Stems

Reference: ‘MOV Stem Lubricant Aging Research’, K. Dewall & J. Watkins, INEEL/EXT – 02-00975, Sep 02. See also MUG File 03J-P21, Handout Jan 2003

Hardware Used; Limitorque SMB-0 actuator equipped with a Reliance 25 ft-lb 480V ac motor.
Stem2, 1.750” diameter, 1/4-pitch, 1/4-lead valve stem and stem nut

Lubricants Tested; Chevron SRI (NLGI Grade 2)
Mobilgrease 28 (NLGI Grade 1½)
MOV Long Life (NLGI Grade 1)

Each lubricant was applied to Stem 2 and tested for a simulated 2½-year period.

MOV Long Life – Stems

Reference: 'MOV Stem Lubricant Aging Research', K. Dewall & J. Watkins, INEEL/EXT – 02-00975, Sep 02. See also MUG File 03J-P21, Handout Jan 2003

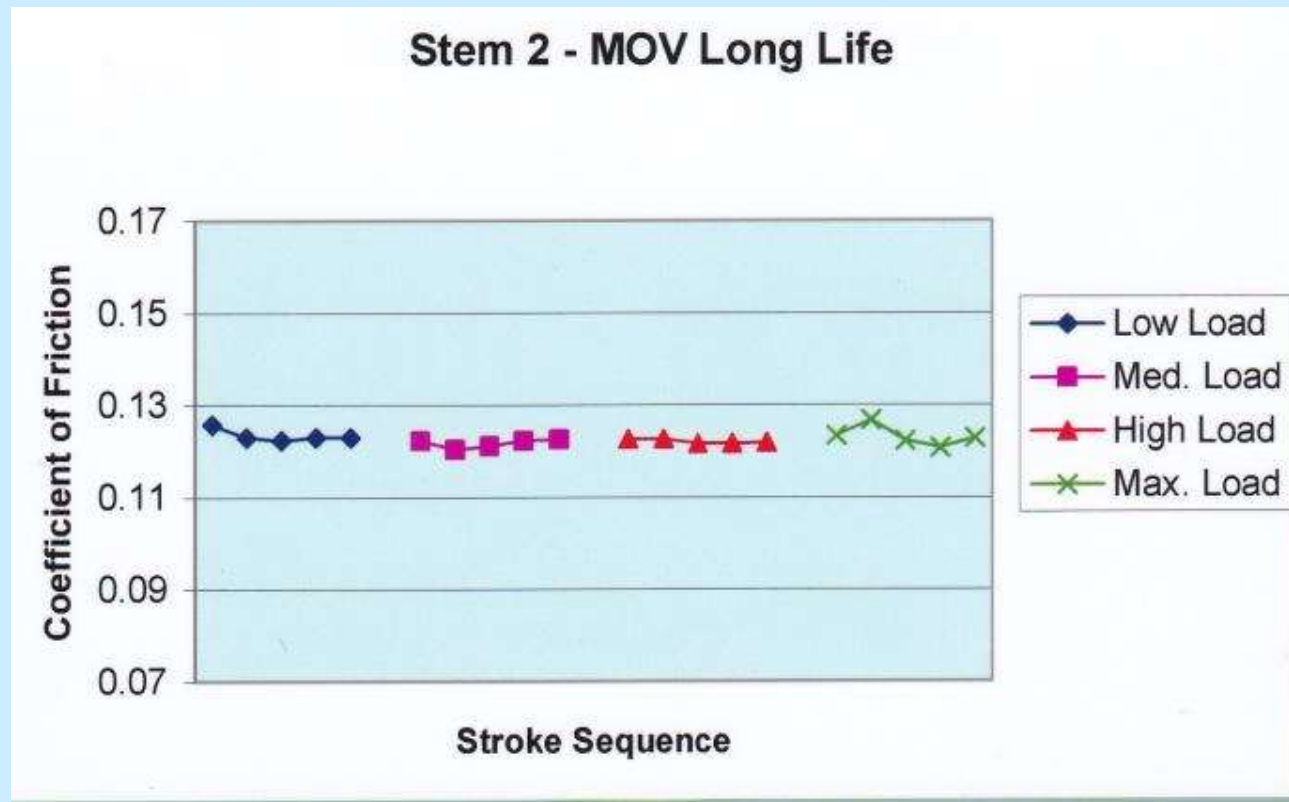

MOV Long Life – Stems

Reference: ‘MOV Stem Lubricant Aging Research’, K. Dewall & J. Watkins, INEEL/EXT – 02-00975, Sep 02. See also MUG File 03J-P21, Handout Jan 2003

- ◆ For Stem 2 with **MOV Long Life**
 - Performance was similar or an improvement over that of other lubricants previously tested.
 - Frictional performance, including rate-of-loading, was stable and repeatable over a wide load range.
 - Elevated temperature resulted in a lower friction coefficient than that observed at room temperature.
- ◆ Stem nut friction appeared to be stable over the simulated aging period.

EPRI - Limit switch gearbox

Reference: NMAC December 2005 Lube Notes – Lube Note Number 4, ‘Substitution of MOV Long Life for Mobilgrease 28 in MOV Limit Switch Gearboxes’

The work was undertaken to qualify **MOV LL** by comparison with Mobilgrease 28 in thermal and radiation exposures simulating service and loss of coolant accident (LOCA) conditions.

This included;

- Bulk oven aging at 150°C (302F) for 300 hours,
- Irradiation to 220 Mrad,
- Thin film tests in air at 149°C (300°F) for 100 hours, and
- Thin film steam tests 149°C (300°F) for 24 hours.

EPRI - Limit switch gearbox

Reference: NMAC December 2005 Lube Notes – Lube Note Number 4, 'Substitution of MOV Long Life for Mobilgrease 28 in MOV Limit Switch Gearboxes'.

The treatments reportedly softened all greases except Mobilgrease 28 which hardened in thin film testing. Mobilgrease 28 was said to get "much harder" in some cases which was said to be a "real disadvantage for M28".

They also found some incompatibility in mixtures between the greases because of softening but it was said to be of little consequence because the grease is contained in the gearbox.

Summary: **MOV Long Life** is an "acceptable replacement for M28 for the MOV limit switch gearbox".

Limitorque Documentation

Technical Update 02-01, Subject: Exxon Nebula EP Grease Replacement

Have **standardized** on **MOV Long Life Grade 0** since 8/29/02. Grade 1 is also acceptable provided the user has successful operating experience relative to the use of Exxon Nebula EP-1. Our Note: MOV Long Life is less prone to tunneling.

Technical Update 04-01, Subject: MOV Long Life / Exxon Nebula EP Grease Compatibility

Based on the EPRI testing Limitorque **authorizes** the mixing of the subject greases in the actuator main gear box.

Letter to BWR Owners' Group, Subject: Replacement Greases for Limitorque Actuators, May 23, 2002

The **recommended** new lubricant for Limitorque SMB, SB, SBD and HBC actuators is MOV Long Life.

Letter to K. Brown, re Millstone Power Station, Subject: MOV Long Life Approval, June 19, 2006

Approved for use in W, B, VG and B230 gear boxes

Our MUG Presentations

'All-in-one, An Update On MOV Long Life', 2003

'MOV Long Life Limitswitch Applications, 2004

'MOV Long Life Condition Monitoring', 2005

'MOV Long Life Condition Monitoring Update', 2006

'MOV Grease Stem Wear Testing', 2007

'Commercial Grade Dedication and In-service MOV Long Life Grease Testing', 2008

'MOV Long Life - Reducing Oil Seepage', 2009

'Semifluid Grease For Oil Filled MOV's', 2010

Summary

- **MOV Long Life** grease has been in use since 2000 and since late 2002 is the factory fill for the main gear box in various Limitorque actuators.
- **MOV Long Life** is the only grease tested and vetted by EPRI to replace Nebula EP and to be used for all three applications on SMB actuators.
- **MOV Long Life** is also being used by other actuators suppliers such as Bernard in France.
- **MOV Long Life** can be suitable for safety related and balance of plant applications including bearings, other gearboxes, and trash rakes.

Lessons Learnt – Oil Seepage

- A few stations had reported oil seepage (leaks) issues. This was with a number of greases.
- This did not affect functionality.
- Some oil separation can be helpful for effective lubrication.
- The known ones had contributing factors which were corrected.

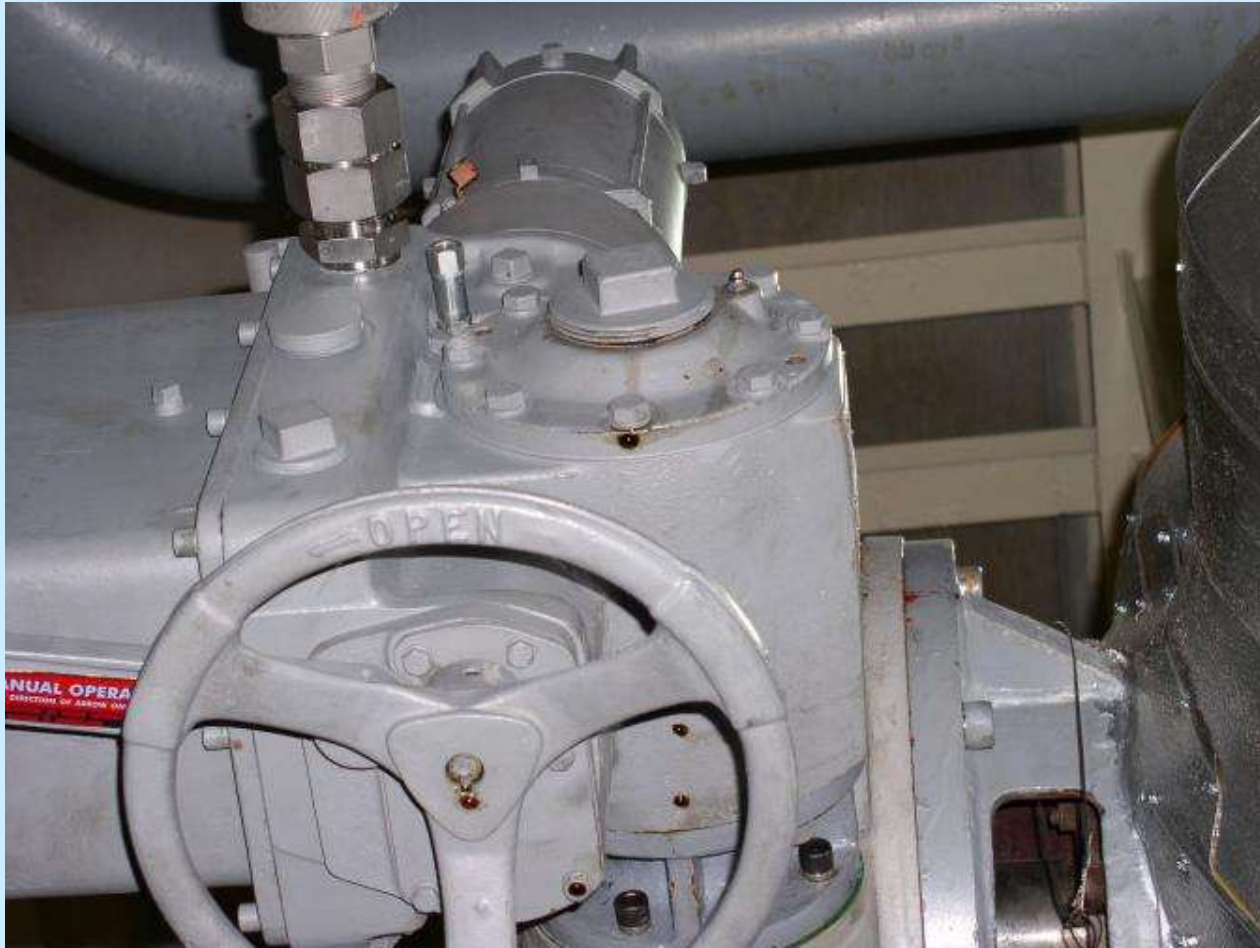

Threaded Plugs

User Quote; "As of today we don't have any sealant recommended for the actuator grease ports."

SOLUTION: USE A SEALANT

Gasket Installation

Subject: Use of grease when installing gaskets

Gasket Manufacture Quote: “This is very bad for the gasket. The gasket will swell.”

“I repeat it is of utmost importance to not use any grease in the application.”

SOLUTION: DO NOT USE GREASE ON THE GASKETS

Gasket Pinching



Fastener Torque

User Quote: "There are no procedural torque requirements for actuator bolting other than the actuator to yoke."

User Quote: "Torquing is performed by good maintenance practice." Might not be good enough.

Use GOOD (new if req'd) fasteners with the RIGHT procedures.

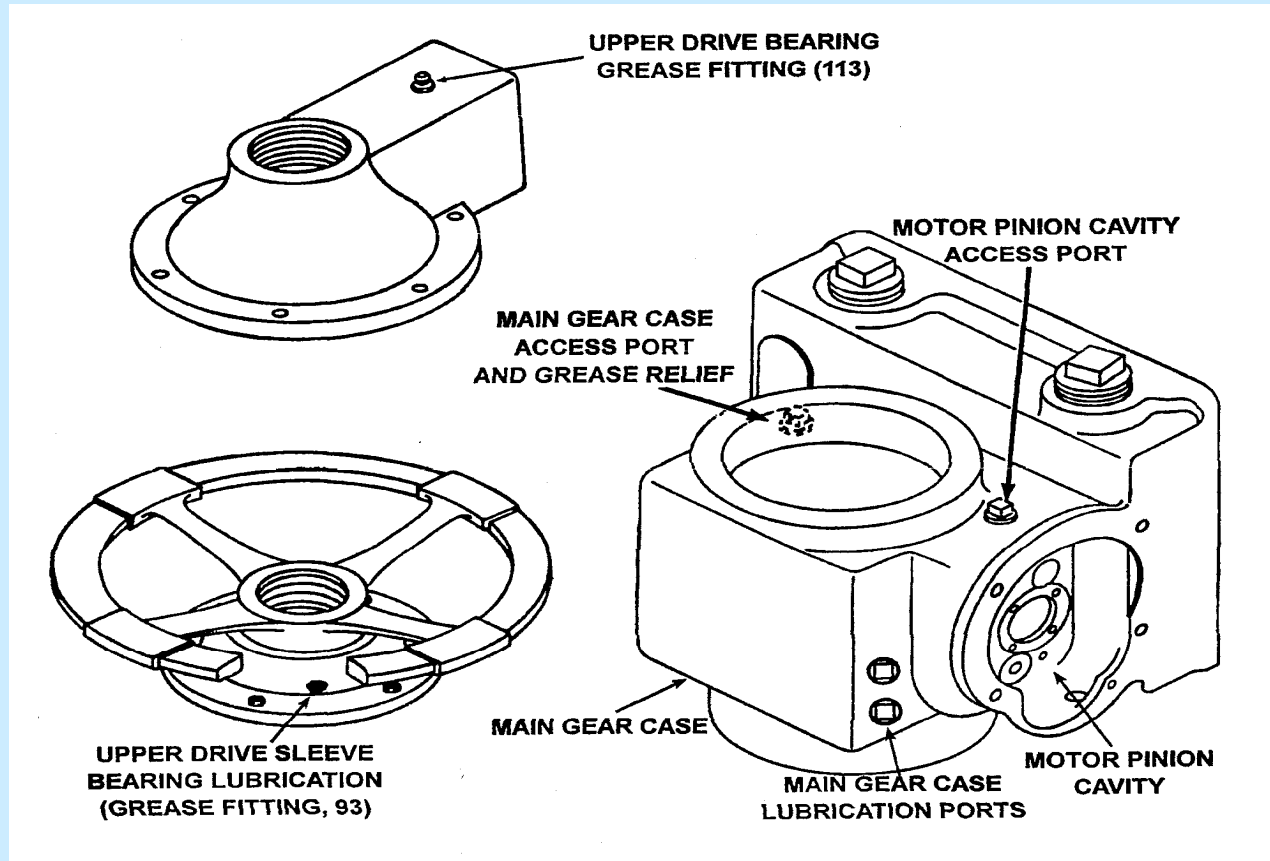

**Solution: Use Grease Relief Valves
When Required**

MOV Extra In-service – Right Amount

A fossil station was using MOV Extra (not nuclear grade but still a calcium sulfonate thickened grease) for use in the main gearbox and the limit switch gearbox for a Limatorque SMB. The application was in a 200°F ambient for about 3 years. The main grease was okay but that in the limit switches was hard. Others using the same grease were reporting good success.

There is not much guidance on how much grease to use. One user specifies 60% while others do not.

Caution: Be sure not to overfill the limit switch gearboxes and do specify how much grease to add.

MOV Long Life In-service – Cost Savings

Dresden have been using MOV Long Life since early 2000 and they provided two samples from the harshest environment for MOV's.

The grease samples were taken during the November 2009 refueling outage thanks to Jason Forsythe.

The valves are located inside the drywell (primary containment) at the highest elevation (4th floor) with normal ambient of 170-205°F in a nitrogen atmosphere. The valves are normally open with a path to the reactor steam volume, but no active steam flow through the line.

(HPCI) Steam Supply In-board Containment Isolation Valve

This is a 10” crane flexible wedge gate valve with a Limatorque SMB-2-60 actuator. The actuator was previously rebuilt every refueling cycle based on the degradation of the earlier grease.

The previous grease was normally very degraded, being black with a burnt smell.

(HPCI) Steam Supply In-board Containment Isolation Valve

MOV Long Life was first used here in the fall of 2001.

A sample is taken every cycle to monitor for degradation and they have had good results. During the November 2009 outage, the actuator grease level was a little low and graded as a 2 (caramel to dark tan), so some grease was added.

This is 4x the life!

Cost Savings

They used to have to rebuild each of these actuators every outage. The parts costs are not high, but the labor is huge.

Estimated to be 200 hours every outage or ~\$15,000 just in labor, with probably another \$1,000 for parts. This is per actuator.

Summary

- There is over 10 years experience with **MOV Long Life** and by all reports it has been performing extremely well.
- A great deal of testing has been done so if you have any questions in this regard just check the websites or let us know. See www.forsythe.on.ca or www.MOVLongLife.com.
- There also still appears to be areas for improvement including; stem nut wear prevention and measurement, fill quantities for limit switch gearboxes, grease application to stems, grease condition monitoring, and semifluid products for oil filled actuators, plus?

THANK YOU