



**2005 MOV Users' Group**

**MOV LONG LIFE GREASE  
CONDITION MONITORING  
TESTS**

Ken Brown\*, Utility Service Associates  
Ted Austin, Forsythe Lubrication Associates  
Wayne Mackwood, Crompton Co

\* toll free 888 442-5008

## BACKGROUND

AT THE LAST TWO MEETINGS INFORMATION HAD BEEN PRESENTED ON HOW MOV LONG LIFE COMPARED AGAINST THE NOW OBSOLETE CALCIUM COMPLEX GREASE AND OTHER GREASES BEING USED IN THE GEARBOXES, LIMIT SWITCHES AND ON THE STEMS OF LIMITORQUE ACTUATORS.

THIS AND TESTING BY EPRI AND COG WENT OUT TO FIVE YEARS AND WHILE SOME OTHER GREASES CHANGED SIGNIFICANTLY, MOV LONG LIFE SHOWED LITTLE DEGRADATION.

\*\*\*\*\*



Photo 1: Calcium Complex EP1



Photo 4: MOV Long Life - 0



Photo 2: Grease 'A'



Photo 5: MOV Long Life - 1, Sample 1

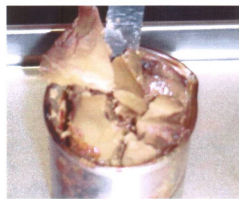

Photo 3: Grease 'B'



Photo 6: MOV Long Life -1, Sample 2

**Bulk Aged Samples: ~66 Hours at 177°C (350°F)**

THE LACK OF DEGRADATION WAS VERY GOOD BUT TO GET AN BETTER UNDERSTANDING OF WHAT CAN HAPPEN THE 'EQUIVALENT' TIME INTERVAL WAS INCREASED TO TEN YEARS.

THE AGED MOV LONG LIFE GREASE WAS THEN TO BE SUBJECTED TO A SERIES OF TESTS THAT MIGHT BE APPLICABLE TO THOSE USED ON THE SMALL SIZE SAMPLES TAKEN FROM IN-SERVICE GEARBOXES.

\*\*\*\*\*

THESE TESTS WERE TO INCLUDE FOURIER TRANSFORM INFRARED (FTIR), HIGH PRESSURE DIFFERENTIAL SCANNING CALORIMITRY (HPDSC), RHEOMETRY, 4 BALL WEAR, TOTAL BASE NUMBER (TBN). AND OTHERS THAT MIGHT BE SUITABLE.

THE EPRI AND COG DATA WAS ALSO REVIEWED TO SHOW WHAT TESTING HAD AND BEEN DONE AND THEIR 5 YEAR AGING RESULTS.

## **EPRI TESTING**

'COMPARATIVE ANALYSIS OF NEBULA AND MOV LONG LIFE FOR LIMITORQUE MAIN GEARBOX APPLICATIONS', #1003483, DECEMBER 2002

AGING:

BULK -300 HOURS AT 150°C (300°C)

THIN FILM – 100 HOURS AT 150°F (300°C)

BULK AGING SAID TO BE EQUIVALENT TO 9 YEARS AT 54°C (130°F) OR 35 YEARS AT 38°C (100°F).

THIN FILM STEAM FOR 24 HOURS AT 150° (302°F)

PLUS 220 MRAD AND EQ

\*\*\*\*\*

## **EPRI TESTS**

- WORKED PENETRATION: ¼ AND ½ SCALE
- WEIGHT LOSS AFTER AGING
- DROPPING POINT (ASTM D2265)
- INFRARED (FTIR) TRACES
- DIFFERENTIAL SCANNING CALORIMETRY (HPDSC)
- RHEOMETER STUDIES – YIELD STRESS
- PIN-ON-DISC (POD) FRICTION &. WEAR STUDIES

# **COG (CANDU OWNERS GROUP) TESTING**

MOV LONG LIFE AND NEBULA\* WERE AGED FOR 660 HOURS AT 130°C (266°F) PLUS 70 MRAD AND LOCA CONDITIONS OF 6 HOURS IN 171°C (340°F) AND 105-KPA (15-PSI) STEAM.

THE AGING WAS TO SIMULATE 5 YEARS OF SERVICE AT TEMPERATURES UP TO 80°C (176°F) FOLLOWED BY A LOSS OF COOLANT ACCIDENT.

\* NEBULA FAILED BY 3½ YEARS.

\*\*\*\*\*

## **COG TESTS**

- PENETRATION (ASTM D-1403)
- RHEOMETRY (BROOKFIELD R/S CONE/PLATE)
- BASE NUMBER
- FOUR BALL WEAR TEST (ASTM D-2266)
- APPEARANCE
- EVAPORATION LOSS (ASTM D-972)
- DROPPING POINT (ASTM D-2265)
- INFRARED
- ROLL STABILITY COMPATIBILITY (ASTM D-1831)

## TEST SAMPLE SIZES

● APPEARANCE	SMALL
● FTIR	TRACE
● HPDSC	1 or 2G
● TACTILE STIFFNESS	SMALL
● BLOTTER TEST	SMALL
● RHEOMETRY	SMALL
● DROPPING POINT	5G
● BASE NUMBER	20G
● EVAPORATION LOSS	25ML
● OIL SEPARATION	100G
● PENETRATION: ¼&½ SCALE	100G
● FOUR BALL WEAR	200G
● DELETERIOUS PARTICLES	200ML
● PENETRATION: FULL SCALE	1LB
● PIN-ON-DISC (POD)	1OZ

\*\*\*\*\*

## WHAT WAS DONE

THE EQUIVALENT IN-SERVICE TIME INTERVAL WAS INCREASED 50% AND 100% MORE THAN USED BY EPRI. THIS WAS TO TEN YEARS AND WAS PERFORMED AT HERGUTH LABORATORIES IN CALIFORNIA.

SAMPLES WERE HEATED AT 150°C (300°F) FOR 300, 450 AND 600 HOURS.

# OXIDATION INDUCTION TIME OF LUBRICATING GREASES BY PRESSURE DIFFERENTIAL SCANNING CALORIMETRY (HPDSC)

THIS TEST METHOD COVERS THE DETERMINATION OF THE OXIDATION INDUCTION TIME OF LUBRICATING GREASES SUBJECTED TO OXYGEN AT 3.5 MPA (500 PSIG) AND TEMPERATURES BETWEEN 155 AND 210°C.

\*\*\*\*\*

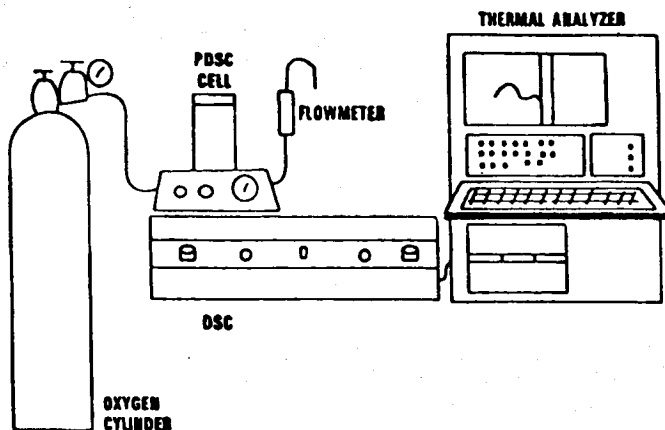

FIG. 1 PDSC Test Unit

## HPDSC

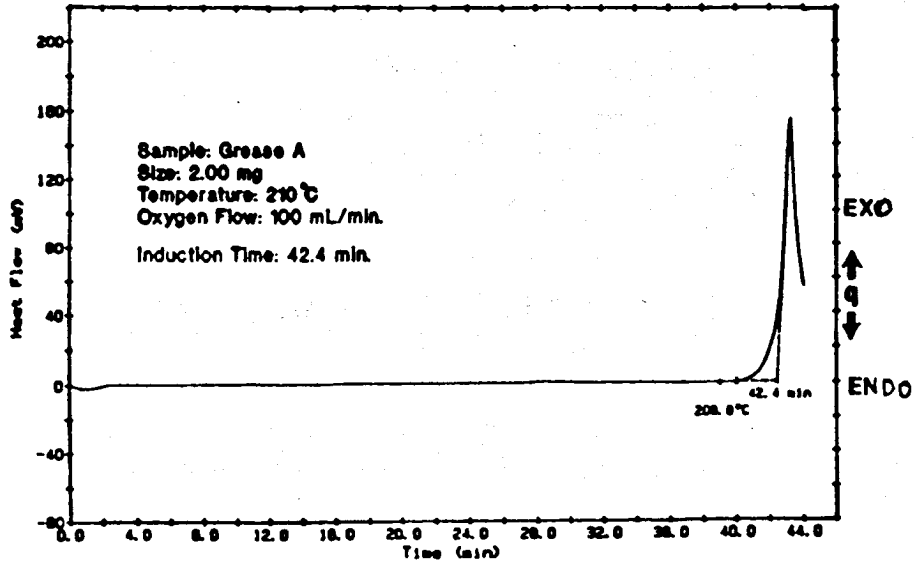

FIG. 4 Typical PDSC Thermal Curve

## OXIDATION INDUCTION TIME

\*\*\*\*\*

## HPDSC

HERGUTH - NOVEMBER 04 (batch K-7-23)

HPDSC TEST TEMPERATURE	AGING*	OIT (MINUTES)**
200C (392°F)	0	24
210°C (410°F)	300	28.82
210°C (410°F)	450	28.78
210°C (410°F)	600	28.77

\* TIME AT 150°C (300°F)

\*\* OXIDATION INDUCTION TIME (LONGER IS BETTER)

# FTIR

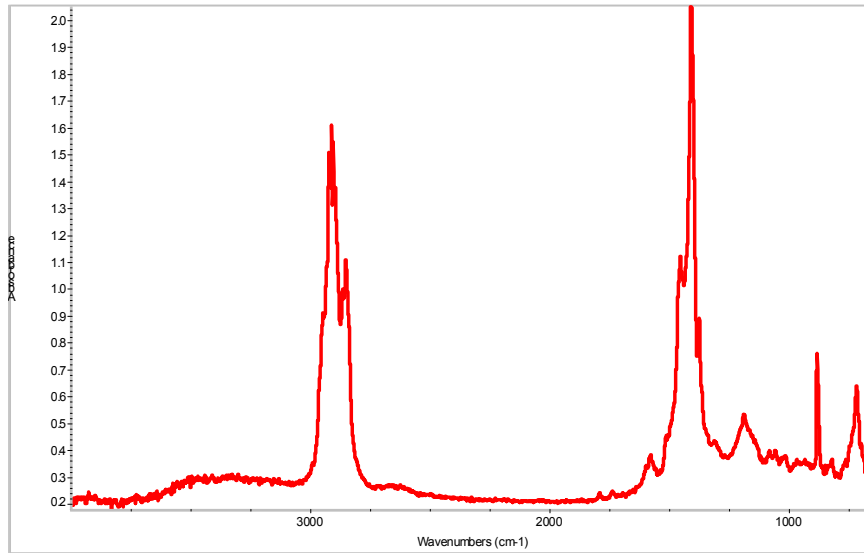

NEW MOV LONG LIFE

\*\*\*\*\*

# FTIR

Conclusion: There is essentially no difference between the samples as they were aged.

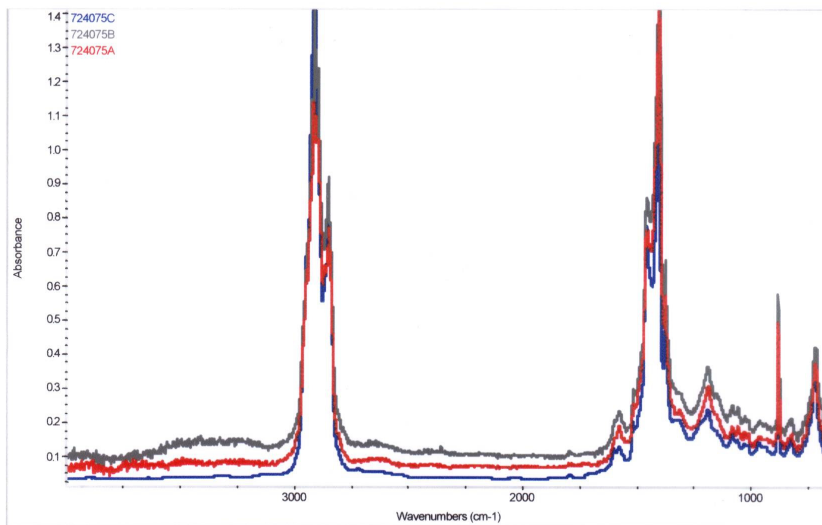

*FTIR SCAN ~4000 to ~700 WAVENUMBERS*

SHOWING NO SIGNIFICANT DEGRADATION

# FTIR

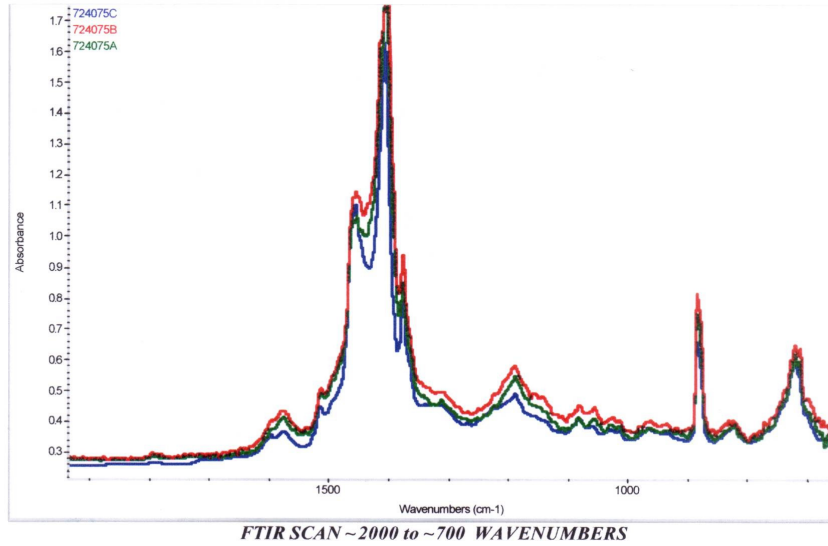

CALCITE  $\sim 880 \text{ CM}^{-1}$

\*\*\*\*\*

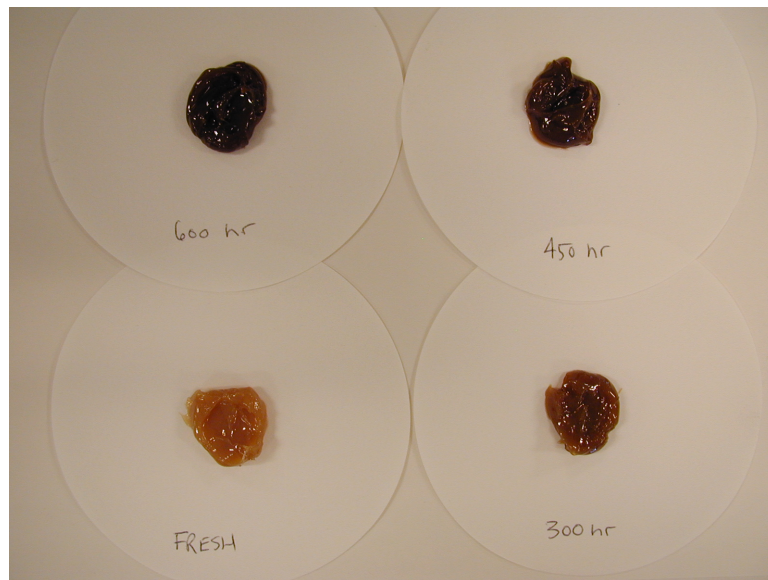

MOV LL BLOTTER TEST  
FRESH AND AGED - START

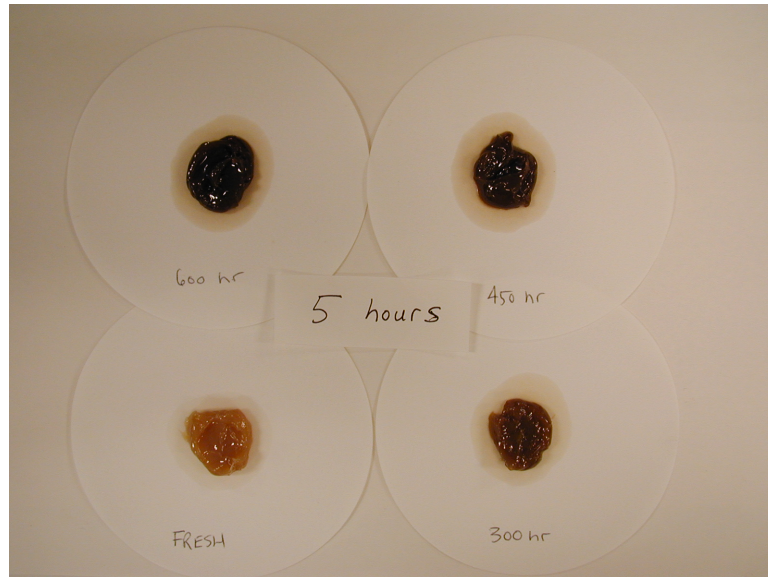

## MOV LL BLOTTER TEST FRESH AND AGED - AFTER 5 HOURS AT RT

\*\*\*\*\*

## 10 YEAR AGING RESULTS

BASED ON HPDSC, FTIR AND APPEARANCE, BLOTTER AND TACTILE TESTING EVEN AFTER 10 YEARS EQUIVALENT AGING, MOV LONG LIFE DID NOT SHOW SIGNIFICANT DEGRADATION.

THIS IS EXCELLENT AND FURTHER TESTING WILL BE PERFORMED TO HELP IDENTIFY A GOOD MOV LONG LIFE IN-SERVICE TEST.

## **OTHER WORK**

THERE HAVE BEEN REPORTS OF OIL BLEEDING OF MOV LONG LIFE FROM TWO SITES. WHILE ALL THE DATA IS NOT AVAILABLE YET IN BOTH CASES THERE APPEARED TO BE CONTRIBUTING FACTORS.

ALSO WHILE THE GRADE 1 WAS USED THERE HAVE BEEN NO REPORTS OF BLEEDING FROM THE GRADE 0 WHICH HAS MORE AVAILABLE OIL.

TO ADDRESS POSSIBLE GREASE ISSUES, PROACTIVE TESTING WAS PERFORMED.

\*\*\*\*\*

## **CAUSE**

OIL BLEEDING IS THE SEPARATION OF THE OIL FROM THE THICKENING AGENT. SOME IS NORMAL AND IS NEEDED FOR LUBRICATION MOV LONG LIFE IS ALSO KNOWN TO BLEED MUCH LESS THAN SOME OTHER GREASES WHICH WERE A 'PROBLEM'.

OIL IS LESS DENSE THAN THE GREASE SO THAT IT WILL RISE TO THE SURFACE OF THE GREASE. FOR IT TO RUN DOWN THE OUTSIDE OF THE GEARBOX REQUIRES A PATH. THIS CAN BE A STEAM NUT SEAL, A GASKET OR A PLUG.

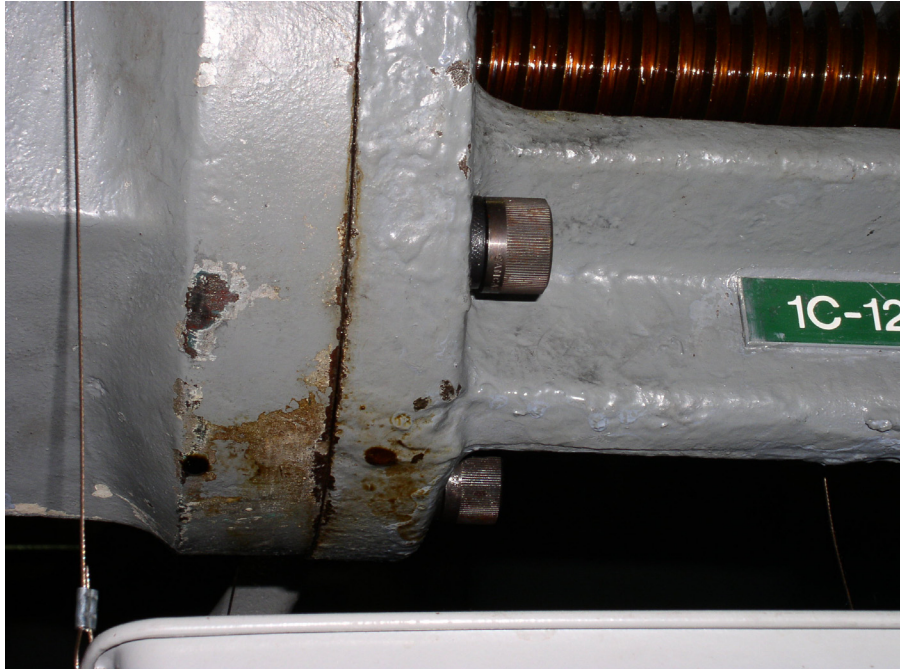

OIL SEEPAGE

\*\*\*\*\*



OIL SEEPAGE

## **ACTIONS**

TESTING WAS DONE AT INDEPENDENT LABS TO DETERMINE;

1. IF OTHER OIL BLEED TESTS GAVE DIFFERENT RESULTS.
2. WHETHER AGED SAMPLES WERE DIFFERENT.
3. IF THERE WAS VARIATION FROM BATCH TO BATCH.
4. IF THERE IS MUCH VARIATION BETWEEN GRADES.

\*\*\*\*\*

## **OIL BLEED TESTS**

**ASTM D1742 - OIL SEPARATION FROM LUBRICATING GREASE DURING STORAGE:** REPORTEDLY A GOOD CORRELATION WITH OIL SEPARATION IN PAILS DURING STORAGE.

ABOUT 300 G OF GREASE IS REQUIRED AND THIS IS PUT INTO A STEEL CONTAINER HAVING ON THE BOTTOM A 74 MICRON (NO 200) STAINLESS STEEL MESH. THE TEST TEMPERATURE IS ONLY 25°C (77°F) BUT THEY APPLY A 1/4 PSI AIR PRESSURE. THE TEST DURATION IS 24 HOURS.

**ASTM D6184 - OIL SEPARATION FROM LUBRICATING GREASE (CONICAL SIEVE METHOD):** THIS IS SAID TO BE VIRTUALLY THE SAME AS THE OLDER FTM (FEDERAL TEST METHOD) 791C METHOD 321.3.

ABOUT 100 G OF GREASE IS REQUIRED AND THIS IS PUT IN A CONICAL SIEVE MADE OF 60 MESH CORROSION RESISTANT WIRE. THE CONE IS SUSPENDED IN A CLOSED CONTAINER AND THE TEST IS NORMALLY RUN FOR 30 HOURS AT 100°C (212°F).

“1.2 This test method is not suitable for greases having a penetration (Test Methods D 217) greater than 340 (softer than NLGI No. 1 grade).

\*\*\*\*\*

**IP (INSTITUTE OF PETROLEUM) 121** - THIS CONSISTS OF STAINLESS STEEL SEPARATION CUP WITH CONE OF 240 MESH WOVEN WIRE CLOTH, 100G METAL WEIGHT AND OIL CUP.

OIL SEPARATION IS DETERMINED BY PLACING THE SAMPLE ON THE WIRE MESH CONE AND LOADING IT WITH THE 100G METAL WEIGHT. THE PERCENTAGE OF SAMPLE CALCULATED AFTER A STORAGE PERIOD OF 42 HOURS. KINECTRICS DID THE TEST AT 100°C (212°F). FOR 30 HOURS.



## ASTM D-1742 STORAGE

\*\*\*\*\*

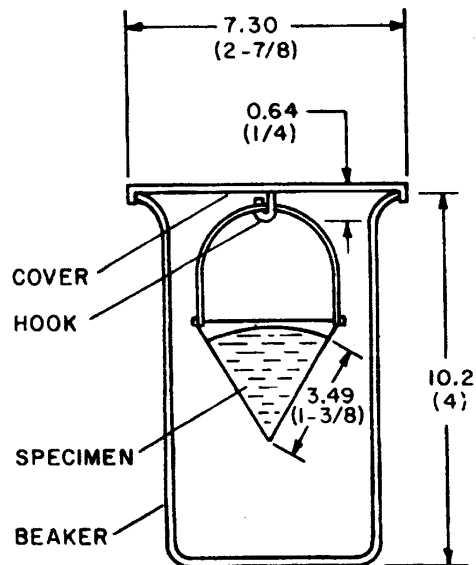

## FTM 321.3 (ASTM D-6184) CONE



ASTM D-6184 CONE

\*\*\*\*\*



IP 121 SIEVE

## EPRI STORAGE OIL SEPARATION TEST ASTM D-1742

THICKENER	% OIL LOSS AT 135°F (HOURS)
CALCIUM SULPHONATE	<0.2 (120)
CALCIUM COMPLEX	3-8 (120)
CLAY	2-6 (120)
POLYUREA	3-14 (120)
LITHIUM COMPLEX	10-20 (48)
ALUMINUM COMPLEX	10 (48)
LITHIUM SOAP	20-35 (48)

‘LIMITORQUE MOV ACTUATOR LUBRICATION - A SINGLE LUBRICANT’,  
EPRI NMAC LUBE NOTES, JULY 1996, VOL.7, NO. 5, PAGES 5-7

\*\*\*\*\*

## STORAGE OIL SEPARATION TEST ASTM D-1742 (% mass) 25°C FOR 24 HOURS

GREASE	% MASS
MOV LONG LIFE GRADE 0	0.39
GRADE 1	0.02
GRADE 2	0.1
MOV EXTRA EP0	1.1
LITHIUM EP0	5.52
CALCIUM COMPLEX EP0	0.33

NLGI ‘GC’ category specify a maximum of 6%

**CONE OIL SEPARATION TEST**  
**ASTM D-6184 (% MASS)**  
**100°C FOR 30 HOURS**

<b>GREASE</b>	<b>% MASS</b>
MOV LONG LIFE EP0	8.3
MOV EXTRA EP0	8.1
LITHIUM EP0	42.7
CALCIUM COMPLEX	4.6

\*\*\*\*\*

**CONE OIL SEPARATION TEST**  
**ASTM D-6184 (% mass)**  
**100°C FOR 30 HOURS**

**MOV LONG LIFE**

<b>GRADE</b>	<b>% MASS</b>
0	8.3
1	9.4 & 5.4
2	3.0

**CONE OIL SEPARATION TEST  
ASTM D-6184**

**MOV LONG LIFE**

<b>DURATION (HOURS)</b>	<b>NLGI GRADE 1 (% BLEED)</b>
24	5.25 4.60 AVG. 4.92
48	6.41 6.26 AVG. 6.34
96	7.58 7.44 AVG. 7.51

\*\*\*\*\*

**NEW DATA  
SIEVE OIL SEPARATION TEST  
IP 121 (% mass)  
100°C FOR 30 HOURS**

<b>GREASE</b>	<b>% MASS</b>
MOV LONG LIFE FRESH	4.1
MOV LONG LIFE COG AGED	4.2

NEW DATA  
**CONE OIL SEPARATION TEST**  
**ASTM D-6184 (% mass)**  
**100°C FOR 30 HOURS**

BATCH	NLGI GRADE	% LOSS
H-6-41	1	3.78
I-8-44	1	2.91
J-2-73	0	7.19
J-5-4	0	9.79
J-5-3	1	6.48
J-8-3	2	1.99
J-11-71	1	5.63
J-11-72	0	8.58
K-2-76	2	1.73
K-3-42	0	6.82

\*\*\*\*\*

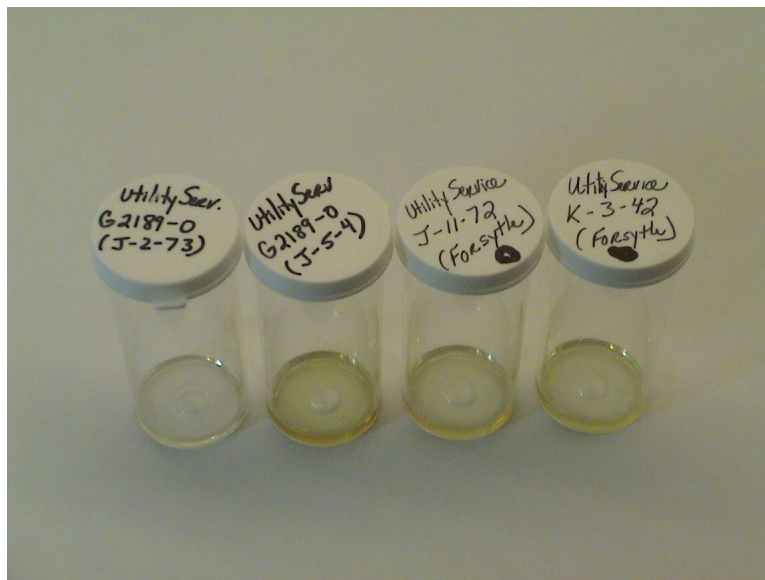

GRADE 0 OIL

## **OIL SEPARATION TEST ASTM D-1742**

MOV LONG LIFE GRADE	AVERAGE % OIL LOSS
0	8.10
1	4.70
2	1.85

\*\*\*\*\*

### **OTHER POSSIBLE FACTORS**

1. TORQUING OF FASTENERS TO COMPRESS GASKETS.
2. GASKET MATERIAL.
3. ORIENTATION.
4. GREASE FILLING OF MOTOR GEARSET COMPARTMENT.
5. HOLLOW SPRING PACK CARTRIDGE SHAFTS

## **CONCLUSIONS**

- 1. AGED AND IRRADIATED GREASE DID NOT BLEED MORE THAN FRESH GREASE.**
- 2. TESTING OF DIFFERENT BATCHES DID NOT SHOW SIGNIFICANT VARIATIONS.**
- 3. DIFFERENT TEST METHODS AND LABS DID NOT SHOW HIGH OIL BLEEDING.**
- 4. CALCIUM COMPLEX GREASE HARDENED MORE AND HAD HIGHER OIL VOLATILITY SO THAT LESS OIL WOULD BE AVAILABLE.**

\*\*\*\*\*

## **CONCLUSIONS CONT'D**

- 5. SEPARATION INCREASES WITH TEMPERATURE, DECREASES WITH TIME AND DECREASES WITH PENETRATION.**
- 6. MOV LONG LIFE REMAINS 'GREASELIKE' LONGER, SO THERE IS MORE OIL AVAILABLE FOR LUBRICATION.**
- 7. AFTER DOUBLE AGING MOV LONG LIFE SHOWED NO SIGNIFICANT DEGRADATION IN THE FTIR AND OXIDATION TESTING (HPDSC).**

## **CONCLUSIONS CONT'D**

**8.** TORQUING OF THE HOUSING BOLTS AND THE GASKETS MIGHT BE IMPORTANT FACTORS TO BETTER CONTROL OIL SEEPAGE.

**9.** THE MOV LL BLOTTER TEST COULD BE DEVELOPED AS A USEFUL FIELD TEST.